

(e-Tender)

BANK NOTE PAPER MILL INDIA PRIVATE LIMITED

Administrative Building,

Gate 1, Paper Mill Compound

Note Mudran Nagar, Mysuru 570003

Phone: 0821-2401 111, FAX: 0821- 2401120

Website: www.bnpmindia.com; Email: scm.tender@bnpmindia.com

Not Transferable

Security Classification: Non-security

TENDER DOCUMENT FOR RE-PAINTING WORK OF SUPPORT STEEL STRUCTURE OF DIESEL GENERATOR CHIMNEY AT BNPM PLANT, MYSURU

e-Tender No. BNPM/OTE/ PAINTING /0513/2022-23 dated: 21.10.2022

This tender document contains 20 pages

The tender documents is issued to

M/s.

Address _____

**Address: Bank Note Paper Mill India Private Limited
Administrative Building
Gate 1, Paper Mill Compound
Note Mudran Nagar, Mysuru - 570 003
Telephone No. 0821 - 2401 111**

LIST OF CONTENTS

Section I	Notice Inviting Tender	Enclosed
Section II	Terms and Conditions	Enclosed
Section III	Technical Specifications	Enclosed
Section IV	Quality Control Requirements	Enclosed
Section V	Qualification /Eligibility Criteria	Enclosed
Section VI	Declarations	
	Annexure – A	Enclosed
	Annexure –B	Enclosed
	Annexure – C	Enclosed
Section VII	Price Bid format	Enclosed

SECTION I - NOTICE INVITING TENDER

1. E-tenders are invited from eligible and qualified tenderers for supply of following goods :

Schedule No.	Brief Description of Goods / Services	EMD**	Required Qty. (Nos.)
1	Re-painting work of support steel structure of diesel generator chimney at BNPM Plant, Mysuru	Not applicable. Bid security declaration is to be submitted.	As per scope of work
Type of Tender (Two Bid / PQB / EOI / RC / Development / Indigenization / Disposal of Scrap / Security item etc.		Two Bid System (Part-I Techno-commercial bid & Part-II Financial /Price Bid)	
Date of Issue of tender documents		From 21.10.2022 to 11.11.2022 (Online)	
Tender Processing Fee		Rs. 100/- + taxes (to be paid online)	
Bid submission mode		Online Through e-tendering portal www.tenderwizard.com/BNP .	
Closing date and time for receipt of tenders		11.11.2022 upto 1100 Hours (Online)	
Opening date and time of tenders		11.11.2022 upto 1130 Hours (Online)	

1. Interested bidders may obtain further information about this requirement from the above office selling the documents. They may also visit our website www.tenderwizard.com/BNP mentioned above for further details.
2. Aspiring Bidders/Contractors who have not registered in e-tendering should register through the website E – Tendering (www.tenderwizard.com/BNP) for participating in the Online Tenders. The registration charges will be Rs. 500/- plus applicable taxes (per year) which needs to be paid through electronic mode only.
3. For details, registration and e-payment, please visit e-tendering website www.tenderwizard.com/BNP or contact KEONICS help desk @ 080-40482000.
4. The NIT Form with standard tender documents will be accessible in the e-Tendering website (viz www.tenderwizard.com/BNP).
5. Class III Digital Signature Certificate (DSC) is mandatory to participate in e-Tenders. Participating bidders/Contractors have to make sure that they have the valid DSC. If not, they can procure from any of the firm as approved by CCA.
6. The tenderer shall satisfy BNPMIPL that they are competent and authorized to submit tender and/or to enter into a legally binding contract with the BNPMIPL. To this effect, any person giving a tender shall render documentary evidence that his signature on the tender submitted by him is legally binding upon himself, his firm or company as the case may be
7. For those tenderers whose technical bids do not satisfy the eligibility criteria, their financial Bids will not be opened.
8. In the event of any of the above mentioned dates being declared as a holiday/ closed day for the purchase organization, the tenders will be sold / received / opened on the next working day at the appointed time.

9. BNPM reserves the right to cancel the tender at any stage without assigning the reasons thereof.
10. The tender documents are not transferable.

Yours faithfully,

For and on behalf of BNPMIPL

Assistant General Manager

SECTION II - TERMS AND CONDITIONS OF THE TENDER

1. Tenders are to be uploaded on e-tendering portal www.tenderwizard.com/BNP only in Two part bid system.

2 i) **Part-I – Prequalification Bid & Techno-commercial Bid**: Scanned copy of Documents towards eligibility criteria, Technical offer (catalogue/brochure etc.), GST, PAN, Bank details etc. along with all sections & annexures of this tender.

ii) **Part II – Price Bid**:

Price Bid shall be submitted through e-portal only, the price bid is liable for rejection if submitted in any other mode. Price Bid should be submitted as per the price bid format provided in Sec – XI, Price Schedule of this tender. Price Bid submitted in any other format will be liable for rejection. Price bids with conditions / Counter conditions are liable for rejection.

3. **Completion Schedule**: Successful bidder shall complete the work within 4 weeks from the date of issue of work order.

4. **Warranty**: Not applicable

5. **Security Deposit / Performance Security**: Not applicable

6. Parties who have been black listed /debarred by BNPMIPL/BRBNMPL/SPMCIL or any PSU or any Government Departments are not eligible for submission of this tender.

7. Bidder may visit BNPMIPL, before submitting the offer after taking due permission for visiting to understand the requirements.

8. No counter conditions shall be accepted.

9. Bidders are advised to write the page number on each page of the Technical Bid documents submitted.

10. BNPMIPL reserves the right to accept the offer by individual items and reject any or all tenders without assigning any reason thereof and does not bind itself to accept lowest quotations.

11. Manufacturer's name and country of origin of materials offered must be clearly specified. Please quote whether your organisation is large scale industry or small scale industry. If you have NSIC/MSE/MSI/DGS&D Certificate, please attach it to the quotation. Mention your registration details.

12. Complete details and ISI specification if any must accompany the quotation. Make/brand of the item shall be stated wherever applicable. If you have got any counter offer as suitable to the material required by BNPM, the same may be shown separately.

13. All drawings, sketches and samples, if any, sent along with this enquiry must be returned along with quotations duly signed.

14. All supplies are subject to inspection and approval before acceptance. Manufacturer/ supplier warranty certificates and manufacturer/Government approved lab test certificate shall be furnished along with the supply, wherever applicable.

15. BNPMIPL reserves the right to modify the quantity specified in this enquiry.

16. The price quoted should be firm till the supplies are completed. Price quoted should be valid for a minimum period of three months from the date of opening of the quotation.

17. **Evaluation of bids :**

(i) The technical bids shall be opened in the first instance and these bids shall be scrutinised and evaluated by the competent committee/ authority with reference to the qualification/ eligibility

criteria prescribed in the tender document. Subsequently, in the second stage the financial bids of only technically acceptable offers as decided in first stage shall be opened for further scrutiny and evaluation. Intimation regarding opening of financial bids shall be given to acceptable tenderers to enable them to attend the financial bid opening, if they so desire.

(ii) All responsive tenderers shall be evaluated as per the terms & conditions of the tender.

(iii) **Price Evaluation criteria:** Price evaluation to determine L-1 status shall be done on the basis of total effective price i.e. Price quoted by the bidder less input GST.

(iv) Bidder has to quote GST rate as per the HSN code provided in Section V: Price Schedule. In case of any mismatch in HSN code with respect to offered product, same shall be decided in consultation with the winning bidder.

18. In case the items in the enquiry are covered by any rate contract or running contract finalised by the DGS&D or any other state or central Government, it should be specified in your quotation and accepted contract rates should also be mentioned. It should be confirmed whether you could supply at the RC rates outside rate contract.

19. Payment of GST is primarily the responsibility of the seller and will not be paid unless the percentage value is clearly mentioned in the quotations. If no indication regarding GST is recorded in the quotation, the GST will be considered as included.

20. Delivery period required for supplying the material should be invariably specified in the quotation.

21. **Liquidated Damage :** In case your quotation is accepted and order is placed on you, the supply against the order should be made within the period stipulated in the order. BNPMIPL reserves the right to recover any loss sustained due to delayed delivery by way of Liquidated Damage. Failure to supply the material within the stipulated period shall entitle BNPM to impose liquidated damages without assigning any reasons @ 0.5% (Half Percent) of the total value of the item covered in order as LD per week or part thereof subject to a maximum of 10% (Five Percent) which you unconditionally and expressly agree to unless extension is obtained in writing from the office on valid ground before expiry of delivery period.

22. **Risk Purchase :** If the successful bidder fails to abide by the terms and conditions of the tender/contract /LOI or fails to provide service as per the tender terms / scope of work / any time repudiates the contract / poor performance / violation(s) of any clause(s) of the agreement or for any bad act of selected bidder / fail to enter into contract agreement within stipulated time , the purchaser(BNPM) will have the right to do the following :

- i. Termination of the contract
- ii. Render service from other agencies at the risk and cost of the successful bidder. The cost difference between the alternative arrangement and existing contract value wherein default has been made will be recovered from the successful bidder along with the other incidental charges.
- iii. In case of rendering service through alternative sources, if price is lower than the existing contract value wherein default has been made, in such case no benefit on this account will be passed on to the supplier.
- iv. Holiday Listing/ Debarment/Blacklisting as per the discretion of BNPM.

23. **Payment terms:** 100% (Hundred Percent) within 30 (Thirty) days on completion of the work and submission of completion certificate issued by BNPM.

24. **Settlement of Disputes through Arbitration:** All disputes and differences of any kind whatsoever arising out of or in connection with the contract, whether during the progress of the work

or after their completion except accepted matters shall be settled through arbitration process as per the Arbitration & Conciliation Act, 1996. The venue of arbitration shall be Mysore, Karnataka

25. Legal Jurisdiction: The Courts of Mysore (Karnataka State) shall alone have jurisdiction to decide on any legal matter of dispute whatsoever arising out or in respect of the contract.

26. Force Majeure: In the event of any unforeseen event directly interfering with the supply of stores arising during the currency of the contract, such as war, hostilities, acts of the public enemy, civil commotion, sabotage, fires, floods, explosions, epidemics, quarantine restrictions, strikes, lockouts, or acts of God, the Contractor shall, within a week from the commencement thereof, notify the same in writing to the Purchaser with reasonable evidence thereof. Unless otherwise directed by BNPM in writing, the supplier shall continue to perform its obligations under the contract as far as reasonably practical, and shall seek all reasonable alternative means for performance not prevented by the Force Majeure event. If the force majeure condition(s) mentioned above be in force for a period of 90 days or more at any time, either party shall have the option to terminate the contract on expiry of 90 days of commencement of such force majeure by giving 14 days' notice to the other party in writing. In case of such termination, no damages shall be claimed by either party against the other, save and except those which had occurred under any other clause of this contract prior to such termination.

27. Termination of Contract for Default:

Without prejudice to any other remedy for breach of contract, such as removal from the list of registered supplier, by written notice of default sent to the supplier, the contract may be terminated in whole or in part:

- i) If the supplier fails to deliver any or all of the stores within the time period(s) specified in the contract, or any extension thereof granted; and
- ii) If the supplier fails to perform any other obligation under the contract within the period specified in the contract or any extension thereof granted.

28. Termination for Convenience (Foreclosure) Clause: BNPM reserves the right to terminate the contract, in whole or in part for its (BNPM's) convenience, by serving written notice on the supplier at any time during the currency of the contract. The notice shall specify that the termination is for the convenience of BNPM. The notice shall also indicate inter-alia, the extent to which the supplier's performance under the contract is terminated, and the date with effect from which such termination will become effective.

29. Rights of Rejection: BNPMIPL reserves the right to reject any or all the applied bids without assigning any reason whatsoever. The enquiry can be rejected on national security grounds.

30. Preference for Micro and Small Enterprises (*MSEs): Public procurement policy for Micro and Small Enterprises (MSEs) order, 2012 as notified by Govt. of India (GOI) along with its amendments as available in www.msme.gov.in shall be applicable to this tender.

31. Labour Laws: The successful bidder shall comply at its own cost with all prevailing statutory provisions as laid down under various Labour Laws like- Minimum Wages Act, 1948, VDA, Provident Fund & Misc. Provisions Act 1952, ESI Act 1948, (successful bidder should have valid PF, ESI Registration), Bonus Act 1965, Gratuity Act 1972, Contract Labour Act (Regulation & Abolition), Workmen's Compensation Act 1923, Factories Act 1948, Industrial Dispute Act, Payment of wages Act 1936, Karnataka Labour Welfare Fund Act and all other applicable statute as applicable & amended from time to time. In case of violation of such statutory provisions under the labour law by the agency, there will not be any liability on BNPM and the contract will be liable for termination.

32. Compensation for damages: In case any damage is caused to BNPMIPL due to negligence, carelessness or inefficiency of staff of the agency, the agency shall be responsible to make good the

loss. BNPMIPL shall have the right to adjust the damage / loss suffered by it or / and to charge penalty as decided by BNPMIPL. Decision of BNPMIPL in this respect shall be final and binding on the agency. The successful bidder shall keep the Purchaser indemnified from any claims whatsoever inclusive of damages/costs or otherwise arising from injuries or alleged injuries to or death , mishap , injury of a person employed by the successful bidder or damages or alleged damages to the property.

33. Successful bidder's responsibility: The successful bidder shall provide everything necessary for the proper execution of the works according to the intent and meaning of the Scope of Work and details taken together whether the same may or may not be particularly shown or described therein provided that the same can reasonably be inferred there from. If the service provider finds any discrepancy in the Scope of Work & details, he shall immediately and in writing refer the same to the BNPMIPL who shall decide which is to be followed.

34. Assignments and subletting/Sub-contracting: The successful bidder in general will not be allowed to assign/ transfer his/ their obligations or benefits either in full or in part to other agency/agencies. Prior approval from BNPM is to be taken for sub-contracting the contract.

35. Tax deduction at source

- a) All statutory deduction as applicable shall be deducted at source as per rules at prevailing rates, unless certificate, if any, for deduction at lesser rate or nil deduction is submitted by the successful bidder from appropriate authority.
- b) The successful bidder shall provide accurate particulars of PAN number as required, under Section 206AA of Income Tax Act 1961.

36. Safety & Security Measures:

- a) The successful bidder should scrupulously conform to the safety and security norms as stipulated by BNPM while working in the security area. The successful bidder shall take all the precaution while executing this work. Protective gears such as Helmets, shoes, belts, gloves etc. (as required) shall be provided by the successful bidder at his own cost to all his workers at site.
- b) The successful bidder shall impose such requirements on all sub-successful bidders also(if applicable). It shall be the responsibility of the successful bidder to ensure that such protective gear is worn at all times by all personnel working at site. BNPM shall have the right to stop any person not wearing such protective gear from working on the site. BNPM is a security organization and its premise is declared as Prohibited Area. Hence the successful bidder has to abide by the security rules of the Company.
- c) The successful bidder shall engage sufficient number of manpower of adult competent and has to ensure the character and antecedent of the persons deployed. Successful bidder should ensure that nothing adverse has been found against them.
- d) In case of accident, including result in any death or disability to the worker the same should be immediately reported to the concerned authority and such other concerned authorities under various labour laws. Any person found under the influence of alcohol or intoxicating drugs on duty is unfit for duty and should not be allowed to work. His work permit should be cancelled and he would be sent out of the premises of the work. 30% of the successful bidder's employee should have training on first aid & fire fighting. Certificates of the same should be produced as & when asked by BNPM.
- e) The successful bidder shall employ only Indian Nationals as his representatives, agent, servant, and workers, verify their loyalty before employing. The successful bidder shall not engage / employ persons below the ages of 18 years. The successful bidder shall employ required number of persons for the proper performance of the services and shall make his own arrangement for his workers. The successful bidder will be responsible for payment of compensation, insurance etc. in respect of his workers and comply with the rules governing the labourers.
- f) If any worker of the successful bidder indulges in theft or any illegal/irregular activities, misconduct, the successful bidder will take appropriate action as per law and rules against its erring workers in consultation with this office and intimate the workers. Such workers, who

- indulge in such type of activities, should not be further employed in this office by the successful bidder in any case.
- g) The successful bidder shall ensure smooth conduct and behaviour on the part of his employees and shall endeavour to maintain discipline and industrial peace. In the event of any strike by the successful bidder's employees, the successful bidder shall ensure that the normal product operations are not affected in any manner by employing workers from an alternate source. In case of his failure to do so, management will deploy the manpower by their own means and debit the cost of the same towards successful bidder's bills.
 - h) The employed contract labour should have valid police verification from the respective police authorities, endorsed by successful bidder before taking them on work at BNPMIPL, Mysore. The expenses for such verification etc are to be borne by the successful bidder and BNPMIPL will not pay anything towards such expenses. If any report found against any contract labour in the duration of the contract, the successful bidder has to remove the employed labour. Contract labour should have police verification from the respective police authorities endorsed by successful bidder before taking them on work at BNPMIPL, Mysore. The expenses for such verification etc. are to be borne by the successful bidder and BNPMIPL will not pay anything towards such expenses.
 - i) The Company reserves its right to advise the successful bidder to remove from service any of the successful bidder's workers if any of such worker's behaviour or conduct is not conducive for the general discipline, safety, hygiene and security of the Company or for any other reasons that the company may deem fit and the successful bidder shall immediately do so.
 - j) The successful bidder must be in a position to produce such documents of fitness whenever asked for to do so. The successful bidder's authorized representative (owner/ director/manager/partner) shall visit at least once in a month at BNPM, Mysore to get feedback of the service rendered by the successful bidder viz-a - vis corrective action required to make service more efficient.
 - k) All materials and articles brought by the successful bidder to the work site shall have to be declared at the Security Gate. Also, no materials shall be taken out from the company premises without proper gate pass/authorization by the competent authority.
 - l) The company being a secured area (declared as Prohibited Area by Govt of Karnataka), restriction of men and materials in to the company premises are very essential both for safety and security point of view. The successful bidder shall strictly follow the administrative and security regulations of BNPM at the site of work regarding entry of personnel, vehicles, materials etc. and other regulations that might be enforced from time to time at the work site for efficient operation.
 - m) The Successful bidder's employees shall be liable to be frisked / checked by the CISF security personnel at BNPM premises or on duty at any time during performance of their duties.
 - n) The material gate pass shall be made by Successful bidder or its representative & shall be cleared by the company-nominated In-charge which will further be regulated by CISF Security at Gate office. The manpower Gate pass shall be prepared by successful bidder, then submitted to the company-nominated In-charge, and then, it shall be recommended to CISF Security on nature of job. Then the In-charge CISF Security shall regulate manpower entry as recommended. Successful bidder shall arrange photo ID passes for its workers. Successful bidder shall arrange photo ID passes for its workers. In case of any doubts, disputes or difference of opinion the CISF manual / circulars on Security procedures shall be the guiding principles to all.
 - o) Note: Working Hours for ladies staff will be from 9:30 am to 6:00 pm.

Guidelines of Sexual Harassment Act 2013

- i. The Bidder shall be solely responsible for full compliance with the provisions of "the Sexual Harassment of women at workplace (Prevention, Prohibition and Redressal Act, 2013". In case of any complaint of sexual harassment against its employee within the premises of the BNPM, the complaint will be filed before the Internal Complaints Committee constituted by BNPM and the Bidder shall ensure appropriate action under the said Act in respect to the complaint.

- ii. Any complaint of sexual harassment from any aggrieved employee of BNPM against any employee/ deputed personnel of the bidder, shall be taken cognizance of by the Complaints Committee constituted by the BNPM.
- iii. The Bidder shall be responsible for any monetary compensation that may need to be paid in case the incident involves the employees / deputed personnel of the bidder, for instance any monetary relief to BNPM employee, if sexual violence by the employee/ deputed personnel of the Bidder is proved.
- iv. The Bidder shall be responsible for educating its employees/ deputed personnel about prevention of sexual harassment at work place and related issues.
- v. The Bidder shall provide a complete and updated list of its employees/deputed Personnel who are deployed within the BNPM premises.

I/we engage to supply the material(s) to your Engineering store, BNPMIPL and comply the following:

1. Tender schedule and technical specification indicated.
2. Item/tender specific conditions for this tender.
3. Terms and conditions enclosed.
4. I/we confirm that set off for the GST, etc. Paid on the inputs have been taken into consideration in the above quoted price and further agree to pass on such additional duties as set offs as may become available in future under GST, etc.
5. This offer is valid for 120 (One hundred Twenty) days from the date of opening of the tender.
6. That we have not been debarred by BNPMIPL/BRBNMPL/SPMCIL and any other Government/Undertakings (Annexure-B enclosed)

Signature & Seal Place & Date:		Name of Authorized Signatory:	
Address:		Tel. No. / Fax. No. / Mobile No.: Email Id:	

SECTION III - TECHNICAL SPECIFICATIONS

1. The Scope of work

- a. Re-Painting work of support Steel structure of Diesel Generator Chimney as per the detail mentioned below.

Chimney Structure Detail is as under.

<u>Description</u>	<u>Details</u>	<u>Remarks</u>
Dimensions (H x B x L)	28.5 x 1.5 x 1.5 (Meter)	Up to 20 Meter height vertical Leg double angle is used.
Ground Support	Bolted to Ground Foundation.	Base Support.
Ladder	Caged Ladder is provided.	For Full Height.
Material of Construction: - (Approximate length of angles are given for estimation, refer drawing for details)		
<u>Description</u>	<u>MOC Details</u>	<u>Remarks</u>
Up to 10 Meter Height	MS Angle: 90x90x8	Vertical Angles Appx. Length: 80 Meters
	MS Angle: 65x65x6	Horizontal & Inclined Bracing Angles Appx. Length: 126 Meters.
10 Meter to 20 Meter Height	MS Angle: 75x75x6	Vertical Angles Appx. Length: 80 Meters (appx.)
	MS Angle: 45x45x6	Horizontal & Inclined Bracing Angles Appx. Length: 120 Meters
20 Meter to 28.5 Meter Height	MS Angle: 65x65x6	Vertical Angles Appx. Length: 72 Meters (appx.)
	MS Angle: 45x45x6	Horizontal & Inclined Bracing Angles Appx. Length: 115 Meters

- b. Surface preparation, Cleaning of Rust by Wire brushing, scrapping or emery paper e.t.c. as required.
- c. Single coat Primer to be applied after surface preparation. Then, after completion of primer application, double coating of Heat Resistant Aluminium Paint to be applied. Time interval between coatings to be given.
- d. All the materials required for rust removal, repainting work, safety Equipments like shoes, safety helmets, Safety belts/Harnesses, PPE, Tools, Painting brushes, emery papers e.t.c shall be scope of bidder.
- e. All safety requirement to be adhered by bidder:
- i. Safety belt must be used for all the jobs to be done at a height of more than 10 feet.
 - ii. Safety belt must be tied to a firm/fixed support.
 - iii. The persons going for height work should have medical fitness certificate.
 - iv. Staging/working Platform/ Scaffoldings shall be arranged by the bidder as per site requirement. Staging & working Platform with fall protection arrangements shall be will be arranged by Vendor as appropriate for works requirement till completion of work.
 - v. Work shall be supervised by the Vendor.
- f. The drawing of Structure is enclosed for reference purposes.

- g. The Bidder must ensure that, all the personnel deployed for painting of Chimney Support Structure on heights must fulfil all the statutory compliances & follow labour compliance as per prevailing laws. Bidder has to submit ESI/ Workmen compensation Policy (as applicable) of all the workforce.
- h. The bidder may visit / inspect the BNPM premises at their own cost with prior permission of BNPM, if required, before submitting the offer.

2. **Scope of BNPM:**

Supply of Heat Resistant Aluminium Paint & Primer for entire work.

(To be signed & stamped and submitted along with Techno-commercial Bid Part -I)

SECTION IV - QUALITY CONTROL REQUIREMENTS & COMPLIANCE STATEMENT

Sl.no.	Description	Bidder Compliance Yes/ No / Deviations
1	Technical specification and scope of work	
Any Deviation from the above specification to be provided below:		
1		

* Bidder has to fill: YES – In case specification remains exactly same in the offered product.
NO - In case specification does not match with the offered product and deviation from the specification to be provided below at the designated place.

B) Commercial Compliance Statement:

Sl. No.	Features	Requirements of BNPMIPL, Terms & conditions	Whether Agreed by the firm	Deviation, if any
1	Payment Terms	As mentioned in Section II	Yes agreed	
2	Liquidated Damages	As mentioned in Section II	Yes agreed	
3	Risk Purchase	As mentioned in Section II	Yes agreed	
4	Delivery schedule	As mentioned in Section II	Yes agreed	
5	Compliance to all other terms & conditions	As mentioned in Section II	Yes agreed	
6	No. of pages	Total number of pages in Technical Bid		

SECTION V – QUALIFICATION/ELIGIBILITY CRITERIA

e-Tender No. BNPM/OTE/ PAINTING /0513/2022-23 dated: 21.10.2022

Category	Eligibility Criteria	Documents required in support of eligibility criteria
General	<p>a) Bidder* (Individual/ firm/ company/ corporate / LLP / HUF / limited company) intending to bid should be bonafide, experienced, technically competent, resourceful and financially sound to carry out the assigned order.</p> <p>*Any bidder from a country which shares a land border with India will be eligible to bid in the tender only if the bidder is registered with the Competent Authority (The Registered Committee constituted by the Department for Promotion of Industry and Internal Trade)</p>	<p>Company's registration / Certificate of incorporation/Partnership Deed/Any other registration certificate as applicable</p> <p>Sealed & Signed Annexure – A on company's letter head.</p>
	b) Bidder should have valid GST registration certificate	Copy of GST certificate
	c) Bidder should have valid PAN card.	Copy of PAN card
	d) Bidder should have not been blacklisted / debarred by BRBNMPL/ SPMCIL/ BNPMIPL/ PSU/Government of India.	Declaration as per Annexure –B on company's letter head duly Signed & with company seal to be submitted
Experience & Past Performance	<p>Bidder should have carried out structural painting work at a height of minimum 30 meter or above, during last five years period ending on 30.09.2022.</p> <p>(A 'year' in this context is a continuous period of 365 days during last 5 years period ending on 30.09.2022)</p>	<p>a) Copy of Work order / Contract</p> <p>b) Documentary evidence towards successful completion of the above (Ref point a) Work order/ Contract</p> <p>c) PF, ESI Registration certificate</p>

SECTION VI - DECLARATIONS

ANNEXURE -A

e-Tender No. BNPM/OTE/ PAINTING /0513/2022-23 dated: 21.10.2022

(To be submitted on the letterhead)

Any bidder from a country which shares a land border with India will be eligible to bid in the tender only if the bidder is registered with the Competent Authority (The Registered Committee constituted by the Department for Promotion of Industry and Internal Trade)

- I) Bidder means any person or firm or company, including any member of a consortium or joint venture (that is an association of several persons, or firms, or companies), every artificial judicial person not falling in any of the descriptions of bidders stated hereinbefore, including any agency branch or office controlled by such person participating in a procurement process.
- II) “Bidder from a country which shares a land border with India” for the purpose of this order means:-
- a) An entity incorporated, established or registered in such a country; or
 - b) A subsidiary controlled through entities incorporated, established or registered in such a country, or
 - c) An entity substantially controlled through entities incorporated, established or registered in such a country, or
 - d) An entity whose beneficial owner is situated in such a country; or
 - e) An India (or other) agent of such an entity; or
 - f) A natural person who is a citizen of such a country; or
 - g) A consortium or joint venture where any member of the consortium or joint venture falls under any of the above.
- III) The beneficial owner for the purpose of (iii) above will be as under :-
- 1) In case of a company or limited liability partnership, the beneficial owner is the natural person (s), who, whether acting alone or together, or through one or more judicial person, has a controlling ownership interest or who exercise control through other means.
- Further explanation:
- a) “Continuing ownership interest” means ownership of or entitlement to more than twenty five per cent of shares or capital or profits of the company;
 - b) “Control” shall include the right to appoint majority of the director or to control the management or policy decision including by virtue of their shareholding or management rights or shareholder agreements or voting agreements;
 - 2) In case of partnership firm, the beneficial owner is the natural person(s) who, whether acting alone or together, or through one or more judicial person, has ownership of entitlement to more than fifteen percent of capital or profits of the partnership;

- 3) In case of an unincorporated association or body of individuals, the beneficial owner is the natural person(s), who , whether acting alone or together, or through one or more judicial person, has ownership of or entitlement to more than fifteen percent of the property or capital or profits of such association or body of individuals;
- 4) Where no natural person is identified under (1) or (2) or (3) above, the beneficial owner is the relevant natural person who holds the position of senior managing official;
- 5) In case of a trust, the identification of beneficial owners(s) shall include identification of the author of the trust, the trustee, the beneficiaries with fifteen percent or more interest in the trust and any other natural person exercising ultimate effective control over the trust through a chain of control or ownership

IV) An agent is a person employed to do any act for any another, or to represent another in dealings with tired person.

V) The successful bidder shall not be allowed to sub contract works to any contractor from a country which shares a land border with India unless such contractor is registered with the Competent Authority.

vi) A bidder is permitted to procure raw material, components, sub-assemblies etc. from the vendors from countries which shares a land border with India. Such vendors will not be required to be registered with the competent authority, as it is not regarded as sub-contracting.

vii) However, in case a bidder has proposed to supply finished goods procured directly/indirectly from the vendors from the countries sharing land border with India, such vendor will be required to be registered with the competent authority.

I have read the above clause regarding restrictions on procurement from a bidder of a country which shares a land border with India. I hereby certify that M/s. is not from such a country or, if from such a country, has been registered with the Competent Authority. I hereby certify that M/s. fulfills all requirements in this regard and is eligible to be considered.” (where applicable, evidence of valid registration by the Competent Authority shall be attached)

I, the undersigned, declare that the item originate in (Name of the country).

Signature _____

Name-----

Designation-----

Date-----

Stamp of the Organization-----

ANNEXURE - B

e-Tender No. BNPM/OTE/ PAINTING /0513/2022-23 dated: 21.10.2022

(To be submitted on the letterhead)

DECLARATION

We do hereby declare that,

1. We have not been blacklisted/ debarred by BNPMIPL/ BRBNMPL/ SPMCIL or any Govt. Departments. The information provided above is correct and true to the best of my knowledge and belief.
2. We do hereby declare that we have read and understood all terms and conditions of tender document including Technical Specification, Quality Control Criteria and confirm to abide to those conditions without any counter conditions.
3. The director/proprietor of the bidding firm are not closely related to BNPMIPL.

In case, at any time the information furnished is found to be false, you may disqualify/ debar me/ us as deemed fit.

Signature _____

Name-----

Designation-----

Date-----

Stamp of the Organization-----

ANNEXURE - C

e-Tender No. BNPM/OTE/ PAINTING /0513/2022-23 dated: 21.10.2022

(To be submitted on the letterhead)

We, the undersigned, declare that we will automatically be suspended from being eligible for bidding in any tender with Bank Paper Mill India Private Limited, Mysore for the period of 12 months, if we are withdrawing our Bid during the period of bid validity (or) fail / refuse to execute the contract, if awarded.

Signature _____

Name-----

Designation-----

Date-----

Stamp of the Organization-----

ANNEXURE D

Tender No: BNPM/OTE/ PAINTING /0513/2022-23 dated: 21.10.2022

Experience & Past Performance detail:

a. Experience Detail

i Order detail:

Sr No.	Work Order/ Contract No & Date	Name of the client issuing the respective order/ contract	Description of work	Contract/ Completion period
1				
2				
3				

b. PF,ESI detail:

Sr No	PF/ESI	Registration No
1	PF	
2	ESI	

Signature _____

Name-----

Designation-----

Date-----

Stamp of the Organization-----

SECTION VII - PRICE BID FORMAT
(TO BE FILLED ONLINE THROUGH E-TENDER PORTAL)

Dear Sir,

Sub: Price bid for Re-Painting work of support Steel structure of Diesel Generator Chimney at BNPM Plant, Mysuru

Ref: e-Tender No. BNPM/OTE/ PAINTING /0513/2022-23 dated: 21.10.2022

We have received and understood the above tender enquiry and are pleased to submit our price bid as under:

Sch. No.	Description	UOM	Qty	HSN/SAC	Basic Unit price (INR)	GST (%)	GST on Unit Price (INR)	Total Unit Price (incl. of GST) (INR)	Less: Input Credit (GST) (INR)	Effective Total Price (net of input tax credit) (INR)
			A		B	C	D=B*C	E=B+D	F	G=E-F
	Re-Painting work of support Steel structure of Diesel Generator Chimney (As per the details provided in Section-III: Technical Specification)	LOT	1							
2	Total price with GST (INR)									
3	Total price with GST (INR) in word									

1. Effective price will be calculated based on Total Price less input GST amount. L-1 status shall be decided considering schedule wise effective total price i.e. line item wise evaluation shall be done. Price quoted is inclusive of all transportation, fooding, lodging, P&F, freight and any other charges
2. Bidder shall note that no extra cost will be considered over and above the price quoted in the price bid and hence bidder shall ensure that price submitted in the price bid is quoted considering complete technical specifications as defined in the tender document.
3. Bidder shall be eligible to pass on the input credit which has been deducted from Total price to arrive at Effective price.
4. Price shall be submitted through e-portal only, the price bid is liable for rejection if submitted in any other mode. Price Bid should be submitted as per the price bid format provided in Sec – XI, Price Schedule of this tender. Price Bid submitted in any other format will be liable for rejection. Price bids with conditions / Counter conditions are liable for rejection. Price bids with conditions / Counter conditions are liable for rejection.
5. Multiple / Variable rate for single item, would lead to rejection of offer.

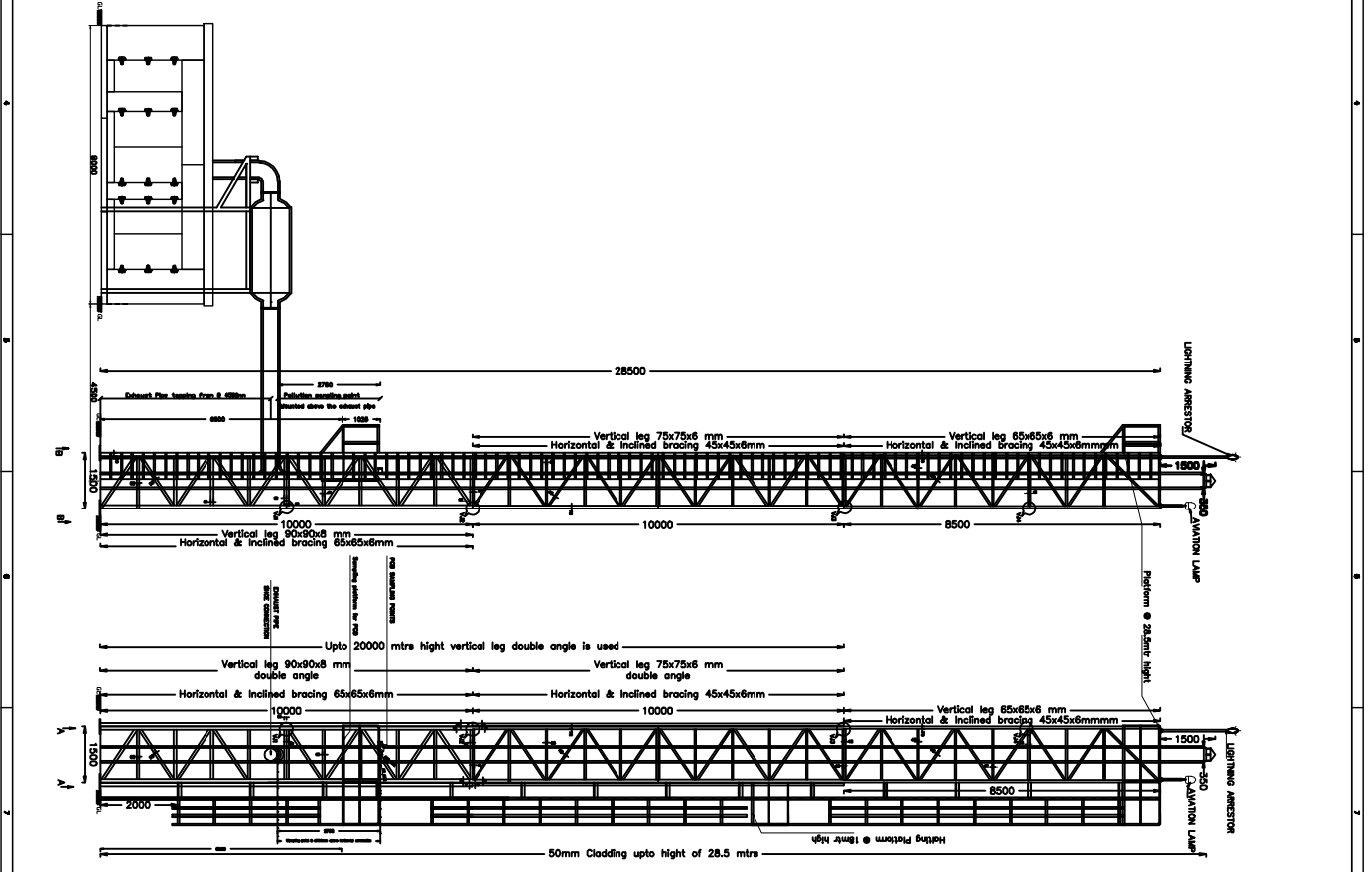
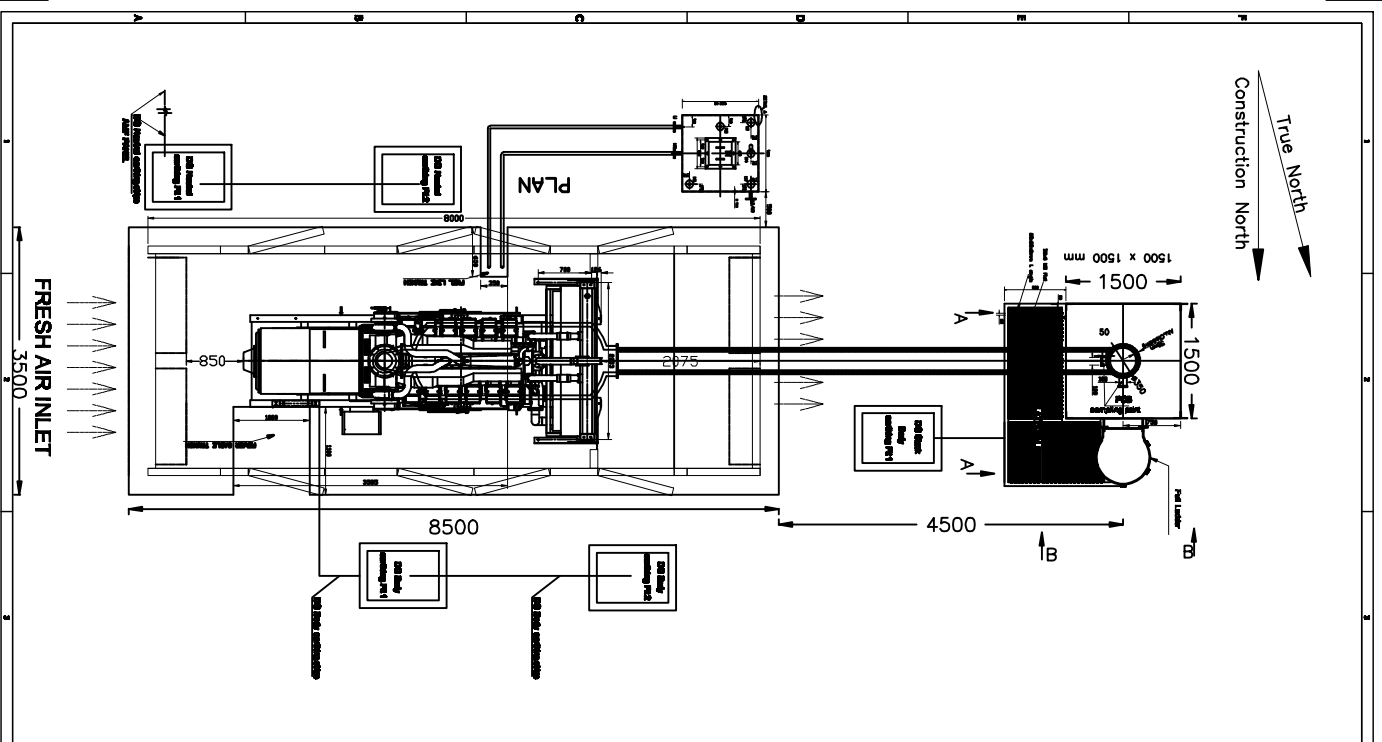

REVISIONS	
NO.	DESCRIPTION
1	ISSUED FOR APPROVAL
2	APPROVED
3	APPROVED
4	APPROVED
5	APPROVED
6	APPROVED
7	APPROVED
8	APPROVED
9	APPROVED
10	APPROVED

1. ALL DIMENSIONS ARE IN MM UNLESS OTHERWISE MENTIONED.

CLIENT:-	BANK NOTE PAPER MILL PVT LTD
CONSULTANT:-	TCE, MUMBAI
PROJECT MANAGEMENT CONSULTANT:-	TCE, MUMBAI
PROJECT VENDOR:-	RAI INDUSTRIAL POWER PVT LTD BANGALORE.
PROJECT:	BANK NOTE PAPER MILL PVT LTD MYSORE
DRAWING TITLE:	QA FOR EXHAUST & FUEL SYSTEM FOR 1000 TPA
DRAWN:	RAJESH
CHECKED:	RAJESH
APPROVED:	RAJESH
DATE:	02-AUG-2014
SCALE:	AS SHOWN
SIZE:	A2
NO. OF SHEETS:	12
TOTAL SHEETS:	12
DATE OF ISSUE:	02-AUG-2014
DATE OF APPROVAL:	02-AUG-2014
DATE OF REVISION:	02-AUG-2014
DATE OF FINAL APPROVAL:	02-AUG-2014

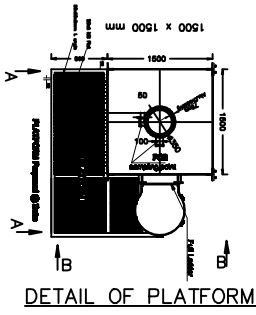
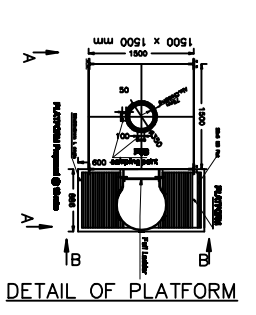
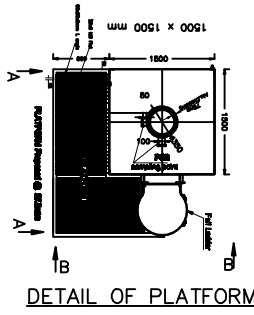
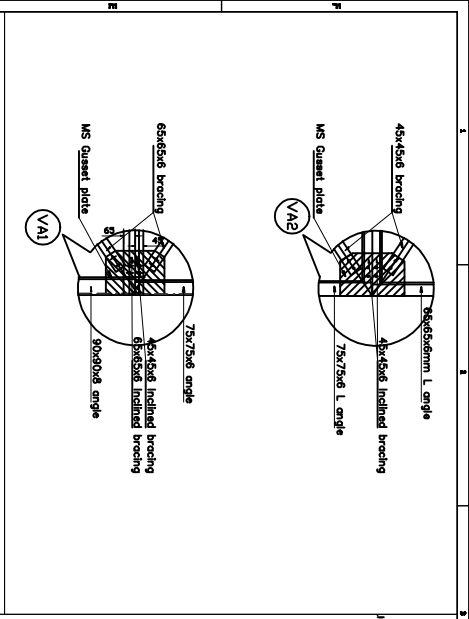

PI-40x6

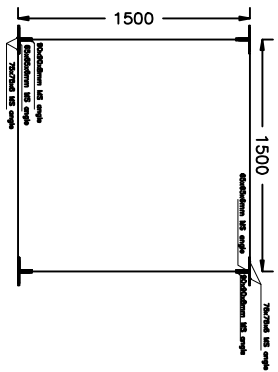
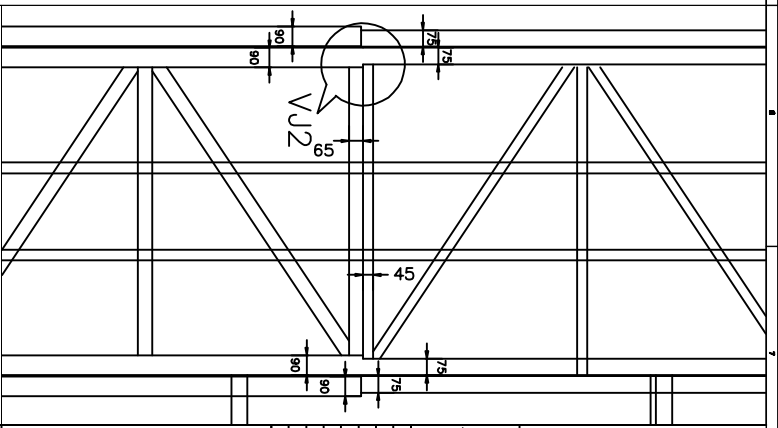
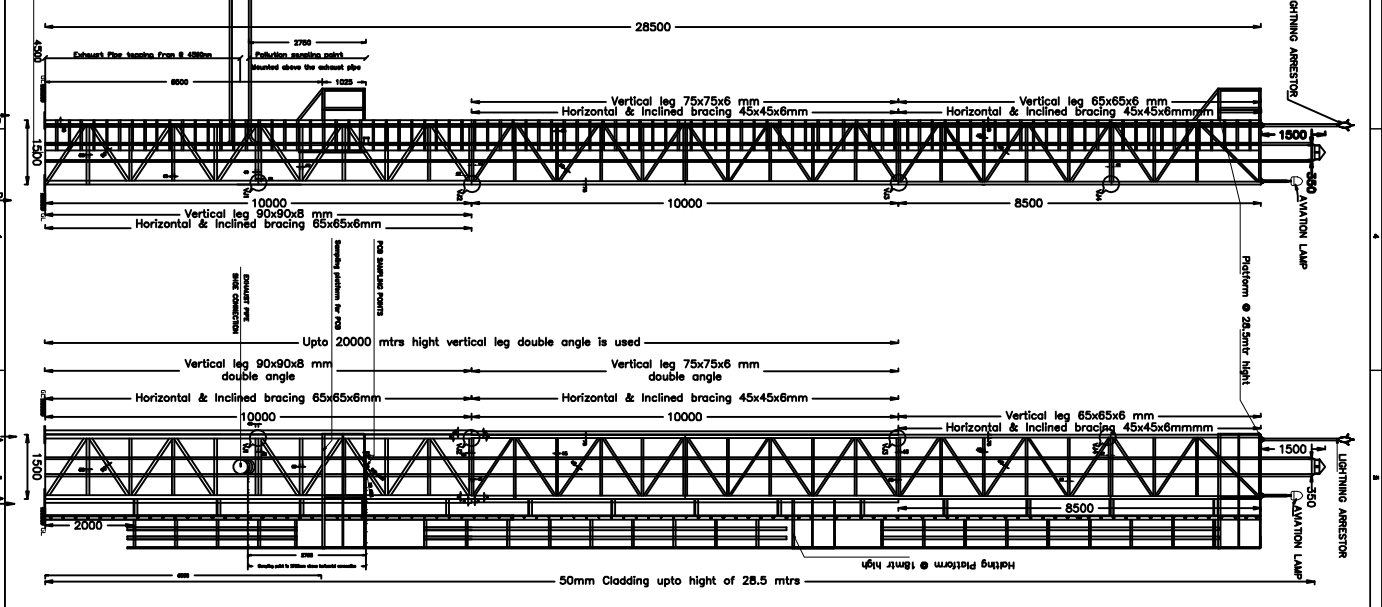

REVISION		DATE	
1	NO	20.04.11	APPROVAL
2	NO	08.07.14	APPROVAL
3	NO	02.07.15	APPROVAL
4	NO	20.04.14	APPROVAL
5	NO	16.04.14	APPROVAL
6	NO	20.04.13	APPROVAL
7	NO	16.04.13	REVISION
8	NO	16.04.13	REVISION

APPROVAL		DATE	
DESIGNED	CHACKED	APPROVED	
DRAWN	RAJESH	REVISION	

PROJECT:	BANK NOTE PAPER MILL PVT LTD
PROJECT TITLE:	MYSORE
CLIENT:-	BANK NOTE PAPER MILL PVT LTD
CONSULTANT:-	TCE, MUMBAI
PROJECT MANAGEMENT CONSULTANT:-	TCE, MUMBAI
GENERAL VENDOR:-	RAI INDUSTRIAL POWER PVT LTD
	BANGALORE

PROJECT:	BANK NOTE PAPER MILL PVT LTD
PROJECT TITLE:	MYSORE
CLIENT:-	BANK NOTE PAPER MILL PVT LTD
CONSULTANT:-	TCE, MUMBAI
PROJECT MANAGEMENT CONSULTANT:-	TCE, MUMBAI
GENERAL VENDOR:-	RAI INDUSTRIAL POWER PVT LTD
	BANGALORE

PROJECT:	BANK NOTE PAPER MILL PVT LTD
PROJECT TITLE:	MYSORE
CLIENT:-	BANK NOTE PAPER MILL PVT LTD
CONSULTANT:-	TCE, MUMBAI
PROJECT MANAGEMENT CONSULTANT:-	TCE, MUMBAI
GENERAL VENDOR:-	RAI INDUSTRIAL POWER PVT LTD
	BANGALORE

PROJECT:	BANK NOTE PAPER MILL PVT LTD
PROJECT TITLE:	MYSORE
CLIENT:-	BANK NOTE PAPER MILL PVT LTD
CONSULTANT:-	TCE, MUMBAI
PROJECT MANAGEMENT CONSULTANT:-	TCE, MUMBAI
GENERAL VENDOR:-	RAI INDUSTRIAL POWER PVT LTD
	BANGALORE